

# PM03C

## Series 3-Phase IED Power Module 690 VAC, Rogowski coils with PT100

Data Sheet

Doc: 40428 v1.06





## INTRODUCTION

The Brodersen LB2 modules can be used with RTU32N & RTU32M series. The I/O modules are in two parts, bottom part containing the backplane bus, and top part containing the I/O board and logic. All LB2 I/O modules are hot plug. LB2 I/O modules are all equipped with 200 MHz processor to process I/O's and handle filtering, de-bouncing, module clock, general module logics, and etc.

Module firmware update is handled from RTU level in Brodersen Worksuite. Use only genuine Brodersen bus cables for connection to Brodersen RTUs and extension of I/O module blocks. The connection cables for LB2 are special made to handle the power requirements and shielding to run communication. The maximum overall length of complete system is 20m. Each I/O module & Power supply module is calculated as 2cm. The cables are as the length indicates, e.g., UCC-610/100 count as 100 cm.

Before using the LB2 Modules, read the LB2 User manual.

Maximum possible system configuration is 60 I/O modules on one LB2 Bus.

## INTRODUCTION TO PM03C

The PM03 Phase Power Measurement Module measures electrical data in a three-phase supply network. The voltage is measured via network connection to L1, L2, L3 and N. The current of the three phases is fed to IL1, IL2, IL3 and IN (two clamping points each + & -) via current transformers or via Rogowski coils. The module transmits metrics (e.g., reactive/apparent/effective power, energy consumption, power factor, phase angle, frequency, over-/undervoltage) directly into the process image, without requiring high computing power from the controller, there is an onboard 2 CPUs one for processing data and one for transmitting to backplane bus.

Comprehensive metrics and harmonic analysis up to the 41st harmonic permit extensive network analysis.

Metrics allow the operator to optimize the supply to a drive or machine, protecting the system from damage and failure. Insulation failures can be detected and prevented via current measurement performed in the neutral conductor.

### Cable ordering codes:

- UCC-610/25 25cm LB2 Cable
- UCC-610/50 50cm LB2 Cable
- UCC-610/100 100cm LB2 Cable
- UCC-610/200 200cm LB2 Cable

## POWER SUPPLY MODULE BACKPLANE PART

Description	Part Nr.
BUS module for IOs, Start	BB21A
BUS module for IOs, Middle	BB21B
BUS module for IOs, Extension	BB21C

## VERSIONS / ORDERING CODES

Hardware basic version

Order code: **PM03C**

## I/O INTERFACE

### Connectors V Input:

1x 4 way 7.5mm pluggable spring clamp connector  
Conductor Area CSA: 6 mm<sup>2</sup>

### Connector's voltage input:

1x 8 way 2.5mm pluggable spring clamp connector  
Conductor Area CSA: 1,5 mm<sup>2</sup>

### Connectors PT100 input:

1x 3 way 2.5mm pluggable spring clamp connector  
Conductor Area CSA: 1,5 mm<sup>2</sup>

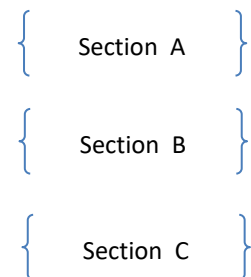

## TERMINALS LAYOUT

### Connector top section A:

- Pin 1: L1 (PHASE 1)
- Pin 2: L2 (PHASE 2)
- Pin 3: L3 (PHASE 3)
- Pin 4: N (Neutral)



**Connector top section B:**

- Pin 1: I1+
- Pin 2: I1-
- Pin 3: I2+
- Pin 4: I2-
- Pin 5: I3+
- Pin 6: I3-
- Pin 7: IN+
- Pin 8: IN-

**Connector Bottom section c:**

Output terminals layout are as follows:

**Connector Bottom:**

- Pin 1 -
- Pin 2 -
- Pin 3 +

**Current transformers connection:**

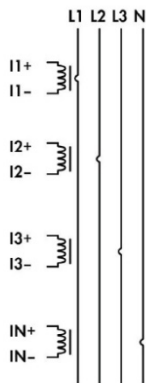

**PT100 connection**

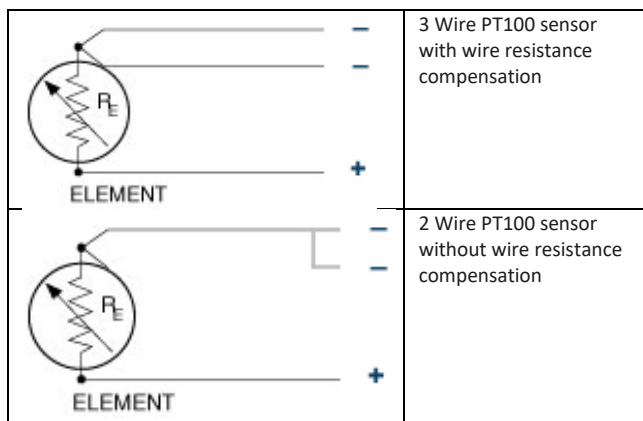

**ELECTRICAL**

**Power consumption (from backplane bus):**

- Current consumption: 125mA (typ.) @ 12V
- Power consumption: 1.5W (typ.)

**POWER MEASUREMENT**

3 voltage measurement inputs, 4 differential current measurement inputs

Signal form:	Any periodic signals
Input resistance voltage path	1429 kΩ
Resolution [bit]	24 Bit
Input resistance current path typ.	> 1MΩ
Maximum secondary voltage of Rogowski coils at measuring current	0.5V AC
Frequency range power supply	45..65 Hz
Frequency range, harmonics analysis	0..3300 Hz (+41 <sup>st</sup> harmonic)
Rated voltage	V <sub>LN</sub> = 400 VAC, V <sub>LL</sub> = 690 VAC
Withstand (Voltage Channel)	2KV Less than 0.5 sec, Non-Recurring

**TEMPERATURE MEASUREMENT**

1 PT100 measurement inputs.

Input	3 wire PT100
Resolution	16 bit
Update time	4 ms
Input resistance current path typ.	22 mΩ
Accuracy (at 25°C)	±0.1%
Temperature drift: ± 25ppm/°C	± 25ppm/°C
Power-freq. noise rejection	50Hz
Measured temperature range	-50 to 300 °C



## MECHANICAL

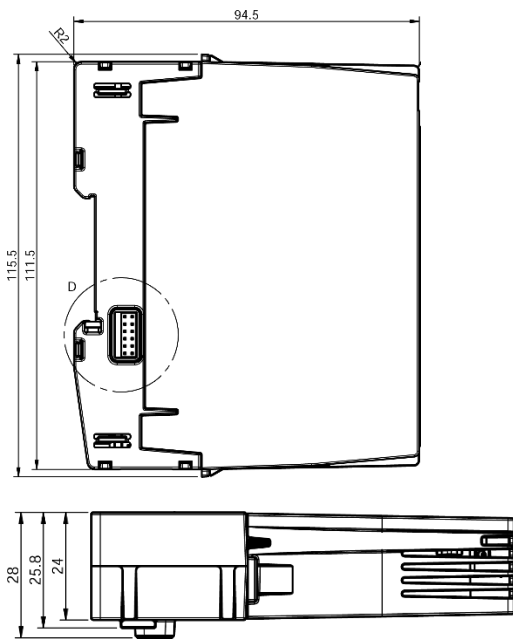

Mounting	DIN 35
Width	24 mm
Height	111.5 mm
Depth	94.5 mm
Weight	102 gram

## ENVIRONMENTAL CONDITIONS

Ambient operating temperature range	-40°C to +85°C
Marked degree of protection	IP20
Humidity	0...99.8%
Ventilation Restrictions	No
Pollution degree	2

## SCHEMATIC DIAGRAM

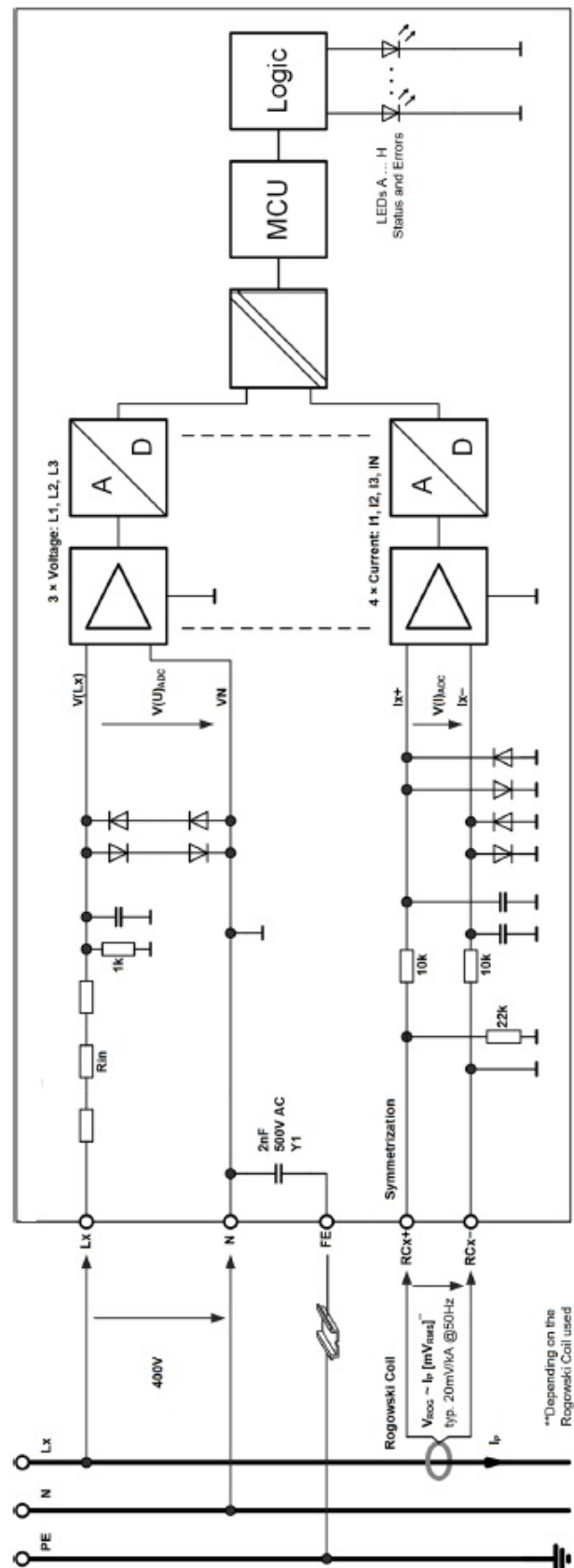



Process data updating:	
Voltage, Lx - N	40 ms
Min./max. voltage, Lx - N	50 ms
Voltage, Lx - Ly	340 ms
Average value, voltage, Lx - N	Adjustable, 5 s ... 900 s
Peak value, voltage, Lx - N	200 ms
Current, Lx	40 ms
Min./max. current, Lx	50 ms
Average value, current, Lx	Adjustable, 5 s ... 900 s
Peak value, current, Lx	200 ms
Current, N	40 ms
Active power, Lx	40 ms
Min./max. active power, Lx	50 ms
Reactive power, Lx	340 ms
Apparent power, Lx	40 ms
Energy meter	400 ms
Line frequency, Lx	280 ms
Min./max. line frequency, Lx	280 ms
Phase angle phi, Lx	340 ms
cos phi	340 ms
PF power factor, Lx	280 ms
LF power factor, Lx	280 ms
Fundamental vibration/upper harmonic	
Current	240 ms
Voltage	240 ms
HD/THD, current	240 ms
HD/THD, voltage	240 ms

Settling times:	
Voltages and currents	620 ms (1300 ms after power-on)
Effective power and apparent power	415 ms at 60 % of P <sub>Full-scale</sub> 915 ms at 100 % of P <sub>Full-scale</sub>
Reactive power	715 ms at 100 % of P <sub>Full-scale</sub> 1215 ms at 100 % of P <sub>Full-scale</sub>
Harmonic analysis	790 ms

## MEASUREMENT ACCURACY

This information applies to both symmetrical and asymmetrical loads. The values indicated only apply if the conditions described in the section "Measurement Errors" are met.

The reference temperature for the temperature coefficient is +25 °C.

AC voltage		
PM03A	± 0.30 % of URV	50 ppm/K temperature drift
PM03B	± 0.30 % of URV	70 ppm/K temperature drift
PM03C	± 0.30 % of URV	50 ppm/K temperature drift
AC current		
PM03A	± 0.30 % of URV	70 ppm/K temperature drift
PM03B	± 0.30 % of URV	90 ppm/K temperature drift
PM03C	± 0.50 % of URV	50 ppm/K temperature drift
AC effective power		
PM03A	± 0.50 % of UR (phase angle ± 5 °)	100 ppm/K temperature drift
	± 0.65 % of URV (phase angle ± 30 °)	
	± 0.75 % of URV (phase angle 0 to 359 °)	
PM03B	± 0.50 % of URV (phase angle ± 5 °)	120 ppm/K temperature drift
	± 0.65 % of URV (phase angle ± 30 °)	
	± 0.75 % of URV (phase angle 0 ... 359 °)	
PM03C	± 0.50 % of URV (phase angle ± 5 °)	90 ppm/K temperature drift
	± 0.65 % of URV (phase angle ± 30 °)	
	± 0.75 % of URV (phase angle 0 ... 359 °)	
Phase angle		
PM03A	± 0.5 °	
PM03B	± 0.5 °	
PM03C	± 1.0 °	



Frequency		
PM03A	± 0.1 Hz	
PM03B	± 0.1 Hz	
PM03C	± 0.1 Hz	
Harmonic analysis measurement, voltage		
PM03A	± 1 % of URV	
PM03B	± 1 % of URV	
PM03C	± 1 % of URV	
Harmonic analysis measurement, current		
PM03A	± 1 % of URV	
PM03B	± 1 % of URV	
PM03C	± 1 % of URV	

\*) "of URV" = of the upper-range value

## STANDARDS

### EMC:

- **IEC 61000-6-2:** EMC - Immunity standard for industrial environments
- **IEC 61000-6-4:** EMC - Emission standard for industrial environments
- **IEC 50121-4:** Railway applications - EMC - Emission and immunity of the signalling and telecommunications apparatus

### Safety:

- **IEC 60950-1:** Safety requirements for Information technology equipment
- **IEC 61010-1:** Safety requirements for electrical equipment for measurement, control, and laboratory use

### Environmental:

- **IEC 60068-2-1:** Environmental testing - Cold
- **IEC 60068-2-2:** Environmental testing - Dry heat
- **IEC 60068-2-30:** Environmental testing - Damp heat, cyclic (12 h + 12 h cycle)
- **IEC 60068-2-78:** Environmental testing - Damp heat, steady state
- **IEC 60068-2-6:** Environmental testing - Vibration (sinusoidal)
- **IEC 60068-2-27:** Environmental testing - Shock

## MODULE LED STATUS

A dual color (red/yellow) LED is provided on the module which indicates the module status. Yellow LED indicates module mode / state and red indicates module error or warnings (according to the table below):

Status	Yellow	Red
Normal operating	ON	OFF
Communication timeout	Blinking	OFF
Module is not configured / wrong configuration	Single flashing	OFF
Module is configured but is in stopped mode (ready for being started)	Double flashing	OFF
Module is in firmware update mode	Quadruple flashing	OFF
Communication error	NA	Blinking
Communication warning	NA	Single flashing
Corrupted module info in EEPROM	NA	Flickering
Hardware fatal error	OFF	ON
No module power	OFF	OFF

Each pattern / color will operate in 2 sec duty cycles. When red LED is inactive (off), only the 2 sec yellow duty cycle will operate (yellow is always active). When red LED is active, a switch between 2 sec yellow, and 2 sec red patterns will occur.