

DI20A, DI20B

Module with 20 Digital inputs

Data Sheet

Doc: 40401-114





INTRODUCTION TO LB2 I/O SERIES

Before using the LB2 Series I/O Modules, read the LB2 User manual.

The Brodersen LB2 modules can be used with the RTU32N and RTU32M series products. The I/O modules are in two parts, a bottom part containing the backplane bus, and a top part containing the I/O board and logic. All LB2 I/O modules are hot pluggable and equipped with a 200 MHz processor to handle filtering, de-bouncing, and logic processing of I/O.

Module firmware updates are managed by the RTU using Brodersen Worksuite. Use only genuine Brodersen bus cables for connection to Brodersen RTUs and extension of I/O module blocks. The LB2 connection cables are made to handle the power and shielding requirements of the LB2 bus communications. The maximum overall length of complete system is 30m. Each I/O module & Power supply module is calculated as 2cm. The cables are as their length indicates, e.g. UCC-610/100 cable is 100 cm.

The maximum number of I/O modules on one LB2 Bus is 60.

Cable ordering codes:

- UCC-610/25 25cm LB2 Cable
- UCC-610/50 50cm LB2 Cable
- UCC-610/100 100cm LB2 Cable
- UCC-610/200 200cm LB2 Cable

POWER SUPPLY MODULE BACKPLANE PART

Description	Part Nr.
BUS module for IOs, Start	BB21A
BUS module for IOs, Middle	BB21B
BUS module for IOs, Extension	BB21C

VERSIONS / ORDERING CODES

Hardware basic version

- Order code: DI20A 10 – 30VDC**
- Order code: DI20B 30 – 60VDC**

I/O INTERFACE

2x 12 way 3.5mm pluggable spring clamp/Screw connectors. The maximum conductor cross sectional area is AWG 16 (1.3mm²). The wire conductor type should be Copper, and it must meet the minimum temperature criteria of 105°C.

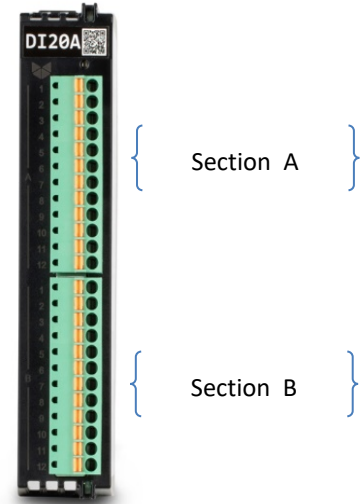

TERMINAL LAYOUT

Connector top section A:

- Pin 1: Common section A
- Pin 2...11: Digital input 0 to 9
- Pin 12: Common section A

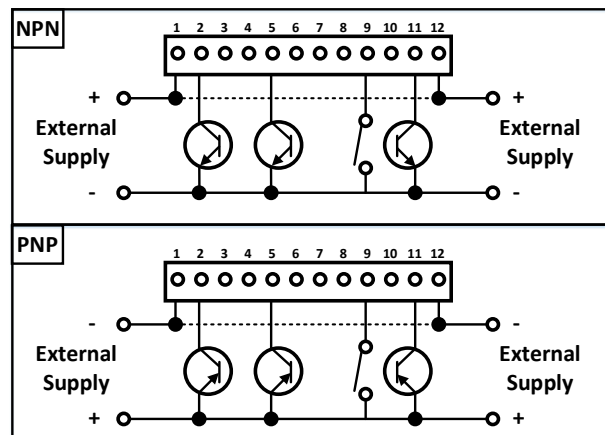

Electrical diagram digital input



Connector bottom section B:

- Pin 1: Common section B
- Pin 2...11: Digital input 10 to 19
- Pin 12: Common section B

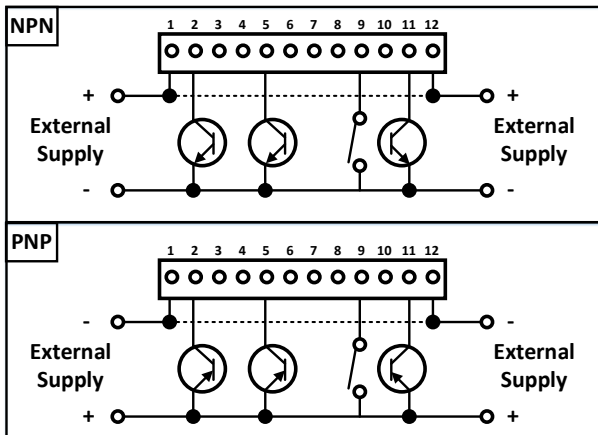

Electrical diagram digital input

ELECTRICAL

Power consumption (from backplane bus):

- Current consumption: 25mA (typ.) @ 12V
- Power consumption: 300mW (typ.)

DIGITAL INPUT

20 bipolar optical isolated digital inputs for 12...24 VDC type A or 48 VDC type B. The module is arranged in two sections of 10 inputs, with 2 common terminals for each section. Each section is isolated from each other and to electronics.

Input 0... 9 and 10...19 provides counters, with up to 100 Hz counting frequency @ 50% duty cycle.

A user programmable debounce filter, in 1ms units, is provided for each digital input, to filter out noise or mechanical relay bounce. This could also be used in combination with software counters, in case a low frequency mechanical contact is used for counters.

Digital input voltage module type DI20A:

- Input 0...9, 10...19 Activated 10-30 VDC
- Input 0...9, 10...19 Deactivated Max 3 VDC

Digital input voltage module type DI20B:

- Input 0...9, 10...19 Activated 30-60 VDC
- Input 0...9, 10...19 Deactivated Max 8 VDC

Digital input current DI20A

- Input 0...7, 10...19 typical 2.5 mA @ 12 V
- Input 0...7, 10...19 typical 5 mA @ 24 V
- Input 8...9 typical 4 mA @ 12 V
- Input 8...9 typical 8 mA @ 24 V

Digital input current DI20B

- Input 0...19 typical 3 mA @ 48 V

Input delay:

100 µs typical.

Isolation:

2.5Kv input to electronics, 1 minute, CH-GND
 Input impedance at nominal voltage for DI20A: 13KΩ
 Input impedance at nominal voltage for DI20B: 40KΩ
 Reverse polarity: Protection for modules

Separated/Safe Extra Low Voltage (SELV) limits:

- VAC (RMS) 30V
- VAC (Peak) 42.4V
- VDC 60V

Note: The SELV limits relies on input supply and all connected voltages.

MECHANICAL

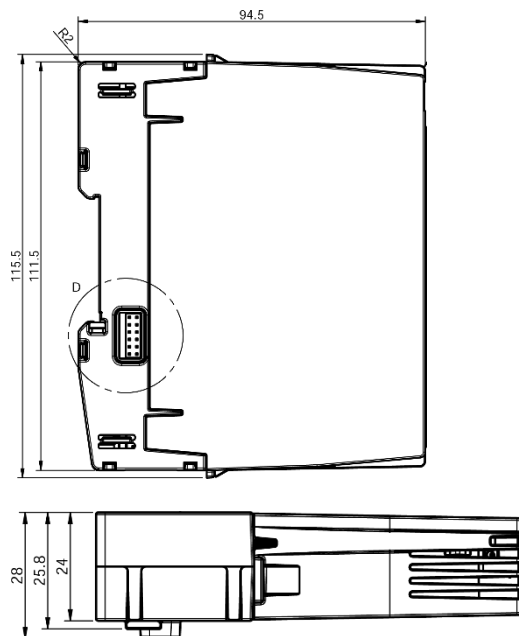

Mounting	DIN 35
Width	24 mm
Height	111.5 mm
Depth	94.5 mm
Weight	102 grams

**ENVIRONMENTAL CONDITIONS**

Ambient operating temperature range	-25°C to +75°C
Ambient storage temperature range	-40°C to +85°C
Marked degree of protection	IP20
Humidity	0...99.8%
Ventilation Restrictions	No
Pollution degree	2

STANDARDS**EMC:**

- **IEC 61000-6-2:** EMC - Immunity standard for industrial environments
- **IEC 61000-6-4:** EMC - Emission standard for industrial environments
- **IEC 50121-4:** Railway applications - EMC - Emission and immunity of the signalling and telecommunications apparatus

Safety:

- **IEC 60950-1:** Safety requirements for Information technology equipment
- **IEC 61010-1:** Safety requirements for electrical equipment for measurement, control, and laboratory use

Environmental:

- **IEC 60068-2-1:** Environmental testing - Cold
- **IEC 60068-2-2:** Environmental testing - Dry heat
- **IEC 60068-2-30:** Environmental testing - Damp heat, cyclic (12 h + 12 h cycle)
- **IEC 60068-2-78:** Environmental testing - Damp heat, steady state
- **IEC 60068-2-6:** Environmental testing - Vibration (sinusoidal)
- **IEC 60068-2-27:** Environmental testing - Shock

MODULE LED STATUS

A dual color (red/yellow) LED is provided on the module to indicate the module status. Yellow indicates the module mode / state and red indicates module error or warnings (according to the table below):

Status	Yellow	Red
Normal operating	ON	OFF
Communication timeout	Blinking	OFF
Module is not configured / wrong configuration	Single flashing	OFF
Module is configured but is in stopped mode (ready for being started)	Double flashing	OFF
Module is in firmware update mode	Quadruple flashing	OFF
Communication error	N/A	Blinking
Communication warning	N/A	Single flashing
Corrupted module info in EEPROM	N/A	Flickering
Hardware fatal error	OFF	ON
No module power	OFF	OFF

Each pattern / color will operate in 2 sec duty cycles. When the red LED is inactive (off), only the 2 sec yellow duty cycles will operate (yellow is always active). When the red LED is active, a switch between 2 sec yellow, and 2 sec red patterns will occur.

SAFETY PRECAUTIONS

- Follow the national safety regulation (IEC 61010-1). 
- Only skilled person is allowed to install and operate the modules.
- Modules can only be mounted in an end-user enclosure which provides protection against fire, electrical and mechanical hazards.
- If the equipment is used in a manner not specified by the manufacturer, the protection provided by the equipment may be impaired.



SOE in LB2 I/O DI series:

The SOE (Sequence Of Events) function is used for storing digital inputs events in a firmware FIFO with 1ms time stamp resolution and status information.

The features of the SOE Driver are:

- Buffering of digital input events in the firmware independent of the PLC runtime application cycle.
- Available for digital inputs on a RTU32M node
- Support debounce and chattering filter functions.
- Each SOE I/O are buffered with four types of information:
 - The DI value (BOOLEAN)
 - Full time stamp (LINT)
 - Blocked status if chattering filters are active (BOOLEAN)
 - Buffer overflow status (BOOLEAN)

SOE buffered data sets in the FIFO buffer are read from the PLC application and each buffered data sets will only be available in one PLC cycle.

Filter functions for SOE

The SOE filter is a multi-stage processing filter that handles the physical value before presenting it as a SOE value. The processing of the value is individually adjustable for each SOE.

Filter block diagram

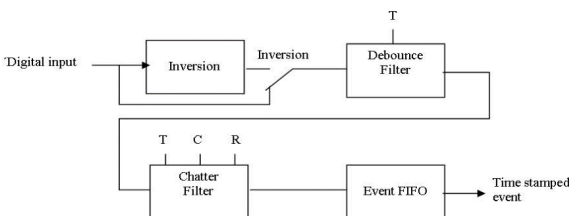

The multistage include the following functions/level before the data sets are sent to the event FIFO:

- Inversion of input value. Used for inverting the input value transmitted to the next level.
- Debounce filter. Debouncing can be used on the first 200 inputs and prevents the processing of fast state changes of the inputs, like for example, those caused by contact bouncing. Signal changes are ignored depending on the present time.
- Chatter filter. Chatter filter can be used for the first 200 inputs. It limits the number of events to a configurable value during a configurable period. This should prevent multiple event registrations for the same input, e.g., disturbance influences due to slowly changing inputs (because the hysteresis is possibly set to small).

Debounce filter function for SOE

An adjustable debounce filter is provided for each digital input. On detection of an input change, a timer with the filter time 'T' is started for the changed input and forwarding of the information is suppressed. If the input changes back to the original state, before the timer has expired, the timer is cancelled. If the input doesn't change back, and the timer expire, the new input state is forwarded. The time stamp forwarded is the time when the actual input change was detected.

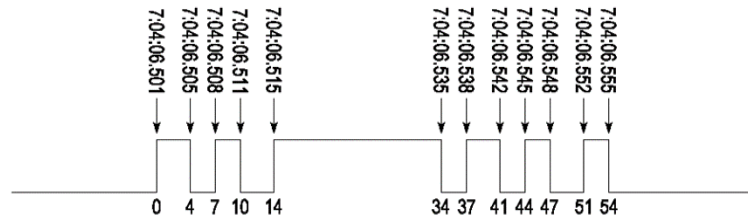

The value range for the filter time is 0 to 32767 milliseconds; the value 0 deactivated the debounce filter.

Figure show example of how SOE events are handled by the filter at T=10ms:

- Stable ON Event at 7:04:06.515 is forwarded at 7:04:06.525, with time stamp 7:04:06.515
- Stable OFF Event at 7:04:06.555 is forwarded at 7:04:06.565, with time stamp 7:04:06.555
- If filter time T=25 milliseconds, no event is recorded with these settings.

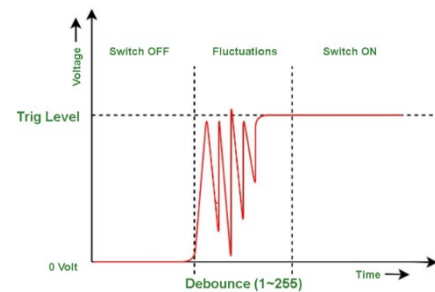

Note:

- The default value for debounce filtering is '0'. To activate it, you need to ensure a stable source voltage. If you have a mechanical interface or unstable input voltage, it is advisable to increase this value.

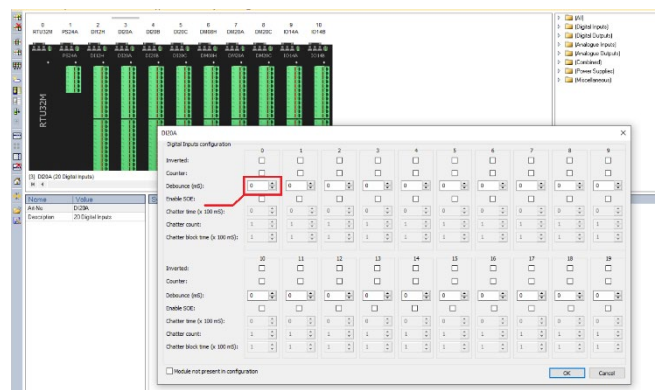



Chatter filter function for SOE

An adjustable chatter filter is provided for each digital input. A digital input is disabled if the number of state changes, encountered during a defined time interval, is excessively high. While the chatter filter is ON, all state transitions are ignored. While it is OFF, state transitions are gated through without further delay. Events are reported whenever the chatter filter state changes from OFF to ON, or from ON to OFF. Three parameters are used to adjust the filter and is individual adjustable for each input.

- **Chatter time [T]:**
The chatter time 'T' defines the minimum time a state must be stable in order not to increment the Chatter times counter when state change occur. However, every time a state is stable longer than the filter time, the Chatter times counter is reset. The filter time is configurable from 0.1 to 6553.5 sec, in units of 100 milliseconds. If set to 0 the chatter filter is disabled.

- **Chatter count (changes) [C]:**
The maximum allowable numbers of consecutive state transitions 'C', that can occur with state width less than the filter time, without turning the chatter filter ON. If the number is exceeded, the chatter filter will turn ON, and any further transitions will be ignored for the duration of the "lock-out" period.
The maximum number of state transitions is configurable from 1 to 255 changes.
- **Chatter block time [R]:**
The chatter block time 'R' is defined as the time during which the chatter filter is ON (if triggered), before turned OFF again. It is programmable from 0.1 to 6553.5 sec, in units of 100 milliseconds.

Chatter function diagram:

